

The Localized Eigenstrain Method for Determination of Triaxial Residual Stress in Welds

Michael R. Hill
University of California, Davis

Drew V. Nelson
Stanford University



Outline

- Nature of weld residual stress
 - ◆ Eigenstrain
- The eigenstrain method
 - ◆ Ueda's "inherent strain" method (1975)
 - ◆ Localized eigenstrain method
- Future Research



Residual Stress in Thick Welds

- Gunnert (1961)
 - ◆ Two-sided butt-weld
 - ◆ 1" plate
 - ◆ Center of length and width

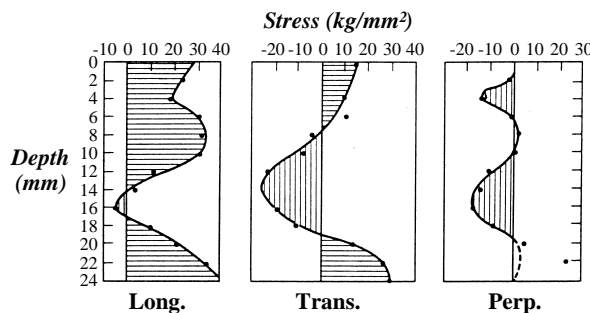
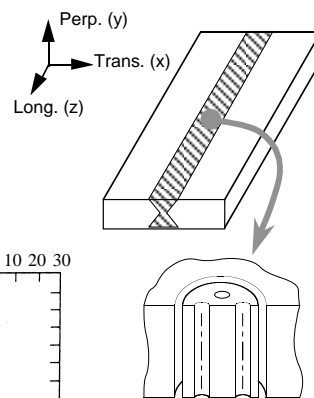

Eigenstrain

- Residual stress exists without applied load
- Strain is the source of residual stress
 - ◆ Result of mechanical or thermal operations
 - ◆ Processes produce strain (deformation)
- "Eigenstrain" or "Inherent strain"
 - ◆ Reissner (1931), Mura (1982), Ueda (1975)
 - ◆ Net effect of all processing
 - ◆ Plastic, thermal, transformation strains

⇒ Residual stress results from eigenstrain, ϵ^*



Elastic Response

- Residual Stress is a *function* of eigenstrain
 - ◆ Equilibrium (Geometry) $\nabla \cdot \underline{\sigma} = \mathbf{0}, \underline{\sigma} \cdot \underline{n} = \mathbf{0}$
 - ◆ Material Model $\underline{\sigma} = \underline{\underline{C}} \cdot (\underline{\epsilon} - \underline{\epsilon}^*)$
 - ◆ “Elastic Response” $\underline{\sigma} = \underline{f}(\underline{\epsilon}^*)$
 - Geometry Dependent
 - Material Dependent

Same eigenstrain field:
Different Geometry \Rightarrow Different Stress



Ueda (1975)

- Sectioning method
 - ◆ Sectioning alters σ but not ϵ^*
- Use FEM to approximate $f(\epsilon^*)$
 - ◆ Spatial interpolation for σ and ϵ^*
- $f(\epsilon^*)$ reduced to linear system
 - ◆ $\underline{\sigma} = \underline{M} \cdot \underline{\epsilon}^*$
- Measured surface stress gives $\underline{\epsilon}^*$
 - ◆ $\underline{\epsilon}^* = \underline{M}^{-1} \cdot \underline{\sigma}$
- Impose $\underline{\epsilon}^*$ on original body to get interior stress



Observations on Welds

- Continuously welded joints
 - ◆ Thermal history independent of cross-section
 - ◆ Similar mechanical restraint
 - ◆ Eigenstrain *independent of position along the weld*

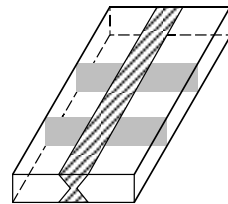

⇒ Stress on longitudinal surface gives ϵ^*



Determination of Weld Eigenstrain

- Block stress
 - ◆ All ϵ^* components
- Slice stress
 - ◆ Planar components
 $\epsilon^*_c = \{\epsilon^*_{xx}, \epsilon^*_{yy}, \epsilon^*_{xy}\}$
- Dice stress
 - ◆ All stress relaxed
- Slice stress gives ϵ^*_c
- Block stress and ϵ^*_c give ϵ^*_{zz}

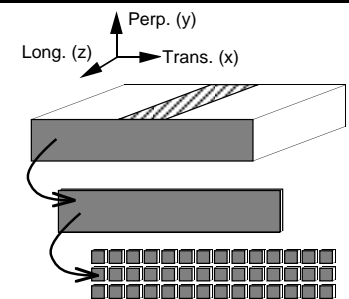

Evaluation of Ueda's Method

- Develop representative $\epsilon^*(x,y)$
 - Detailed FEM
 - ◆ Find free surface stress
 - Apply Ueda's method
 - ◆ Use free surface stress
 - ◆ Estimate interior stress
- ⇒ Compare Ueda estimate to detailed FEM

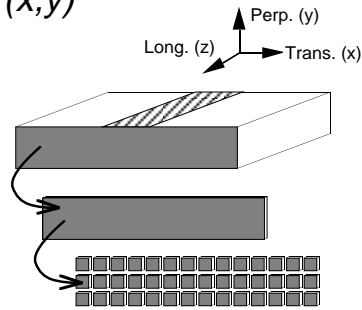

Stress Produced by $\epsilon^*(x,y)$

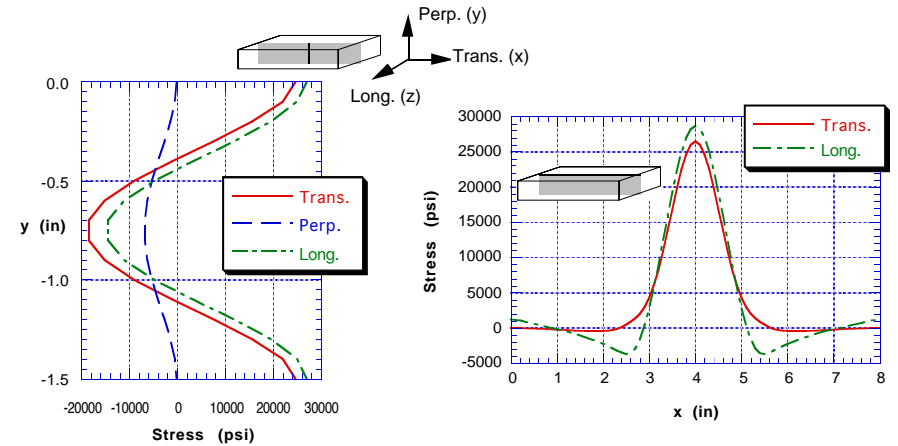

FEM compared to Ueda Estimates

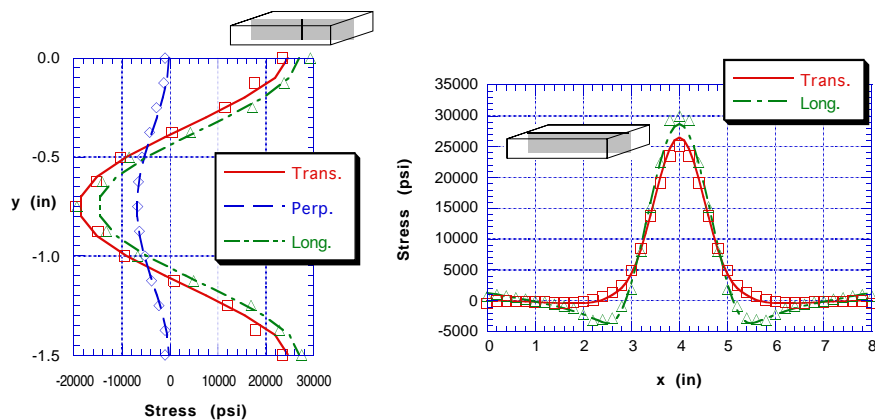

Variation of Eigenstrain in z

- Examine slice from weld center

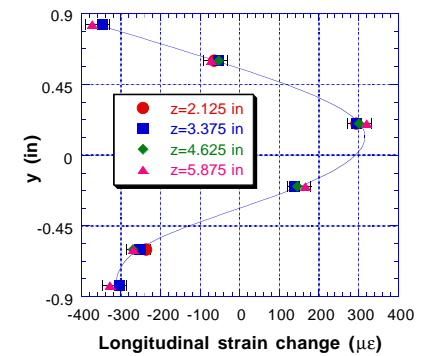
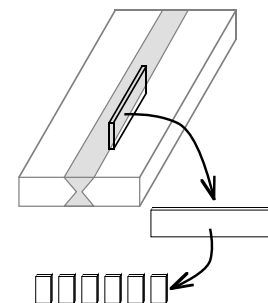

Eigenstrain is independent of longitudinal position



Discussion of the Eigenstrain Method

- Results in the entire joint
- Numerical experiments show good accuracy
- Basic assumption well-founded
- Complex method
- Requires exhaustive sectioning, instrumentation, and analysis (FEM)

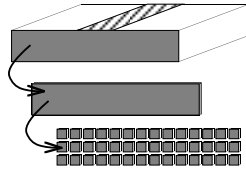

Localized Eigenstrain Technique

- Region of interest for a weld is small
 - ◆ Defects only occur close to the bead
 - ◆ For assessment, find stress near the weld bead

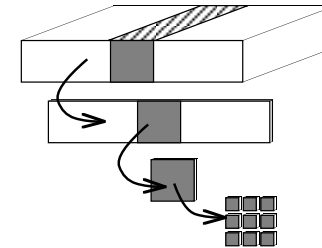

Instrument only a small area

Overview of the Localization

- Separation of ϵ^*
 - ◆ Outside the region of interest
 - ◆ Within the region of interest
 - Effective in chunk
 - Ineffective in chunk
 - ◆ Optimize discretization for each component of ϵ^*

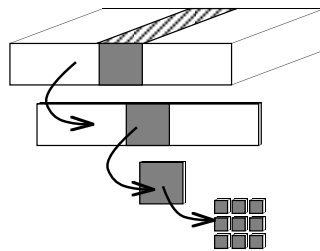

Localized Method Applied to the Weld

- Relative to previous method:
 - ◆ Less error
 - 8% vs. 17% maximum
 - ◆ Fewer measurements
 - 51 vs. 340 gages
 - ◆ Less sectioning
 - ◆ Less analysis
 - 147 vs. 500 interpolation parameters

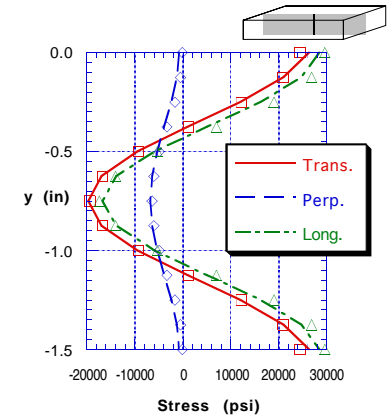

Conclusions

- Residual stress is caused by eigenstrain, ϵ^*
- Sectioning alters residual stress but not ϵ^*
- The eigenstrain approach:
 - ◆ Estimates residual stress by finding ϵ^* experimentally
 - ◆ Relies on a verifiable assumption: $\epsilon^*(x,y)$
- A localized eigenstrain method was developed
 - ◆ Gives results only in the bead region of the weld
 - ◆ Reduces the effort required greatly
 - ◆ Estimates interior stress with good accuracy

